

## Straight Perforated

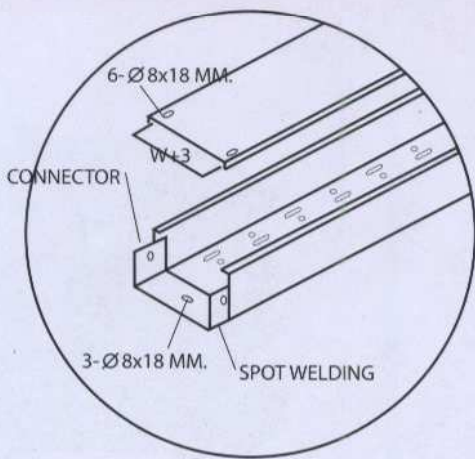

- MATERIAL** : Cold roll steel , Hot roll steel , Stainless steel
- FINISHING** : EC (Epoxy powder coating)  
 HD (Hot dipped Galvanized)  
 AL (Aluzinc)  
 GI (Zinc)
- COLOUR** : เทาเรียบ , เทาขุ่น , ครีมขุ่น , ครีมเรียบ , ขาวเรียบ
- THICKNESS** : 0.8 , 1.0 , 1.2 , 1.6 , 2.0 mm.

Code No.	Width (mm.)	Height (mm.)	Length (mm.)
PT 1	75	50	2440
PT 2	100	50	2440
PT 3	100	75	2440
PT 4	100	100	2440
PT 5	150	100	2440
PT 6	200	100	2440
PT 7	250	100	2440
PT 8	300	100	2440
PT 9	350	100	2440
PT 10	400	100	2440
PT 11	450	100	2440
PT 12	500	100	2440
PT 13	550	100	2440
PT 14	600	100	2440
PT 15	650	100	2440
PT 16	700	100	2440
PT 17	750	100	2440
PT 18	800	100	2440
PT 19	900	100	2440
PT 20	1000	100	2440

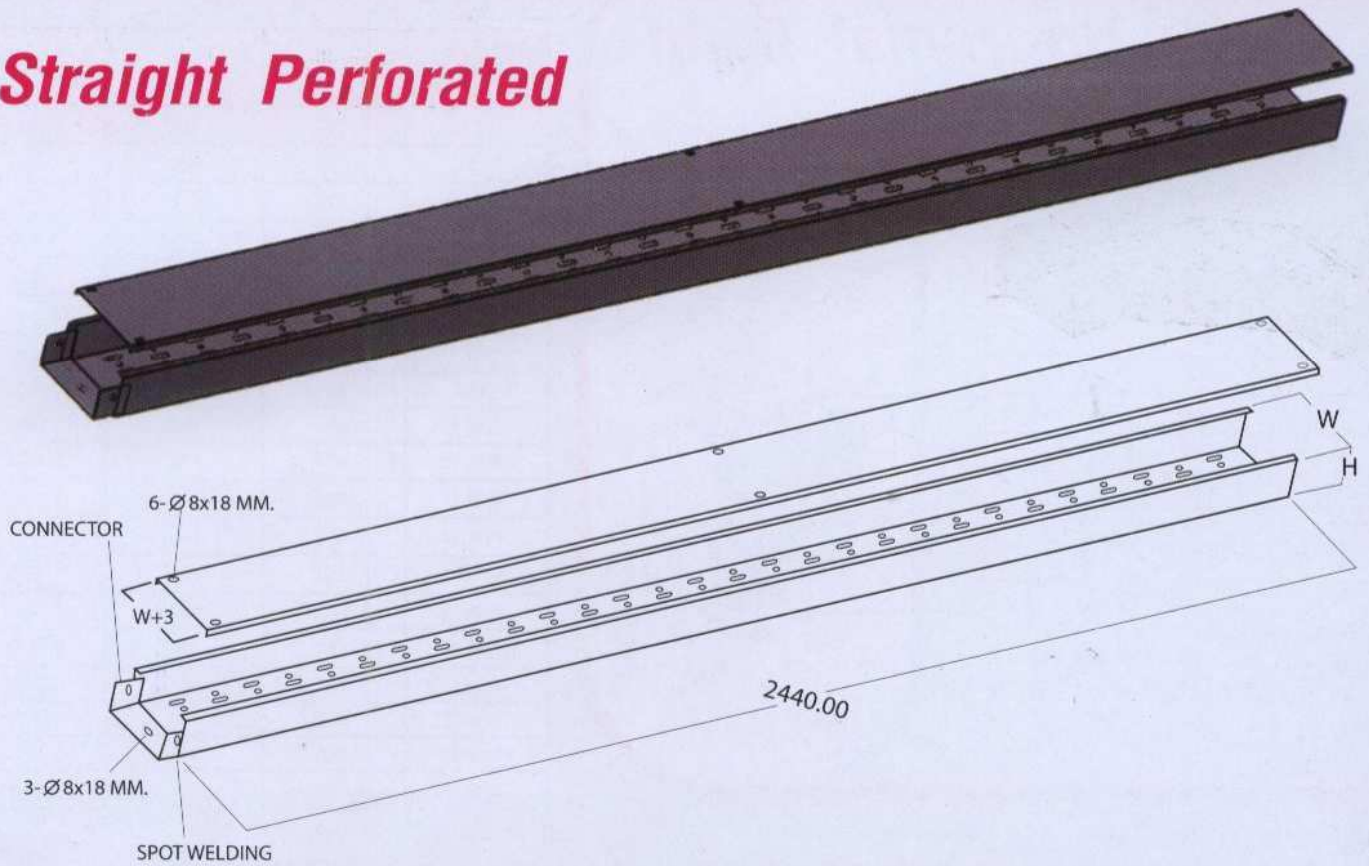

## 90° Horizontal Bend

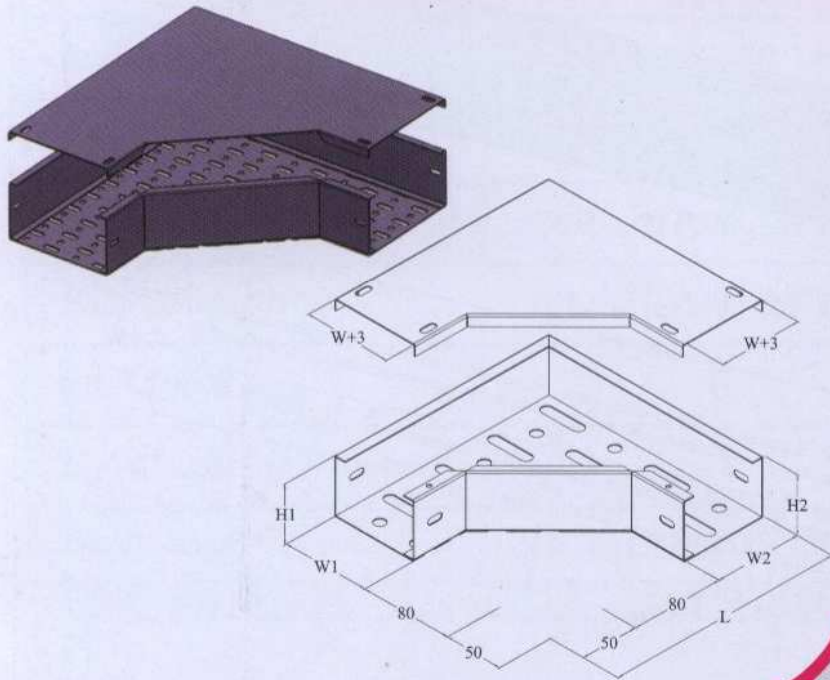

Code No.	Width (mm.)	Height (mm.)	Length (mm.)
PHB 1	75	50	205
PHB 2	100	50	230
PHB 3	100	75	230
PHB 4	100	100	230
PHB 5	150	100	280
PHB 6	200	100	330
PHB 7	250	100	380
PHB 8	300	100	430
PHB 9	350	100	480
PHB 10	400	100	530
PHB 11	450	100	580
PHB 12	500	100	630
PHB 13	550	100	680
PHB 14	600	100	730
PHB 15	650	100	780
PHB 16	700	100	830
PHB 17	800	100	930
PHB 18	900	100	1030
PHB 19	1000	100	1130

**MATERIAL** : Cold roll steel , Hot roll steel , Stainless steel  
**FINISHING** : EC (Epoxy powder coating) , HD (Hot dipped Galvanized) , AL (Aluzinc) , GI (Zinc)  
**COLOUR** : เทาเรียบ ,เทาเข้ม , ครีมน้ำเงิน , ครีมน้ำเงิน , ขาวเรียบ  
**THICKNESS** : 0.8 , 1.0 , 1.2 , 1.6 , 2.0 mm.

Code No.	Width (mm.)	Height (mm.)	Length (mm.)
PHT 1	75	50	205
PHT 2	100	50	230
PHT 3	100	75	230
PHT 4	100	100	230
PHT 5	150	100	280
PHT 6	200	100	330
PHT 7	250	100	380
PHT 8	300	100	430
PHT 9	350	100	480
PHT 10	400	100	530
PHT 11	450	100	580
PHT 12	500	100	630
PHT 13	550	100	680
PHT 14	600	100	730
PHT 15	650	100	780
PHT 16	700	100	830
PHT 17	800	100	1060
PHT 18	900	100	1160
PHT 19	1000	100	1260

## Horizontal Tee

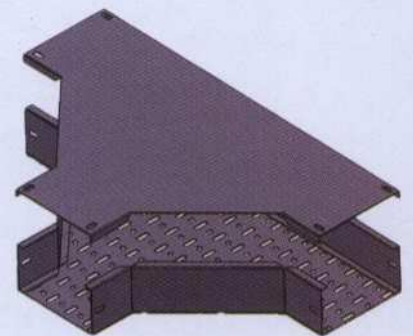
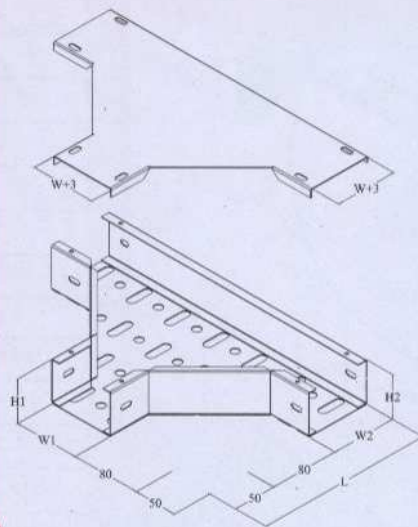

**MATERIAL** : Cold roll steel , Hot roll steel , Stainless steel  
**FINISHING** : EC (Epoxy powder coating) , HD (Hot dipped Galvanized) , AL (Aluzinc) , GI (Zinc)  
**COLOUR** : เทาเรียบ ,เทาเข้ม , ครีมน้ำเงิน , ครีมน้ำเงิน , ขาวเรียบ  
**THICKNESS** : 0.8 , 1.0 , 1.2 , 1.6 , 2.0 mm.



## 90° Vertical Inside

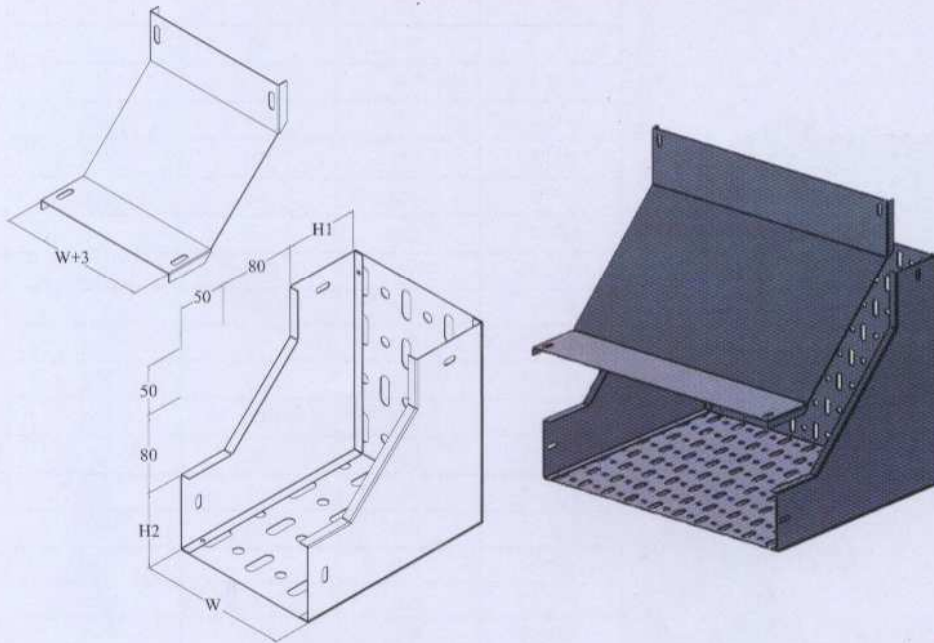

Code No.	Width (mm.)	Height (mm.)
PVI 1	75	50
PVI 2	100	50
PVI 3	100	75
PVI 4	100	100
PVI 5	150	100
PVI 6	200	100
PVI 7	250	100
PVI 8	300	100
PVI 9	350	100
PVI 10	400	100
PVI 11	450	100
PVI 12	500	100
PVI 13	550	100
PVI 14	600	100
PVI 15	650	100
PVI 16	700	100
PVI 17	800	100
PVI 18	900	100
PVI 19	1000	100

**MATERIAL** : Cold roll steel , Hot roll steel , Stainless steel  
**FINISHING** : EC (Epoxy powder coating) , HD (Hot dipped Galvanized) , AL (Aluzinc) , GI (Zinc)  
**COLOUR** : เทาเรียบ , เทาขุ่น , ครีมนุ่น , ครีมเรียบ , ขาวเรียบ  
**THICKNESS** : 0.8 , 1.0 , 1.2 , 1.6 , 2.0 mm.

Code No.	Width (mm.)	Height (mm.)
PVO 1	75	50
PVO 2	100	50
PVO 3	100	75
PVO 4	100	100
PVO 5	150	100
PVO 6	200	100
PVO 7	250	100
PVO 8	300	100
PVO 9	350	100
PVO 10	400	100
PVO 11	450	100
PVO 12	500	100
PVO 13	550	100
PVO 14	600	100
PVO 15	650	100
PVO 16	700	100
PVO 17	800	100
PVO 18	900	100
PVO 19	1000	100

## 90° Vertical Outside

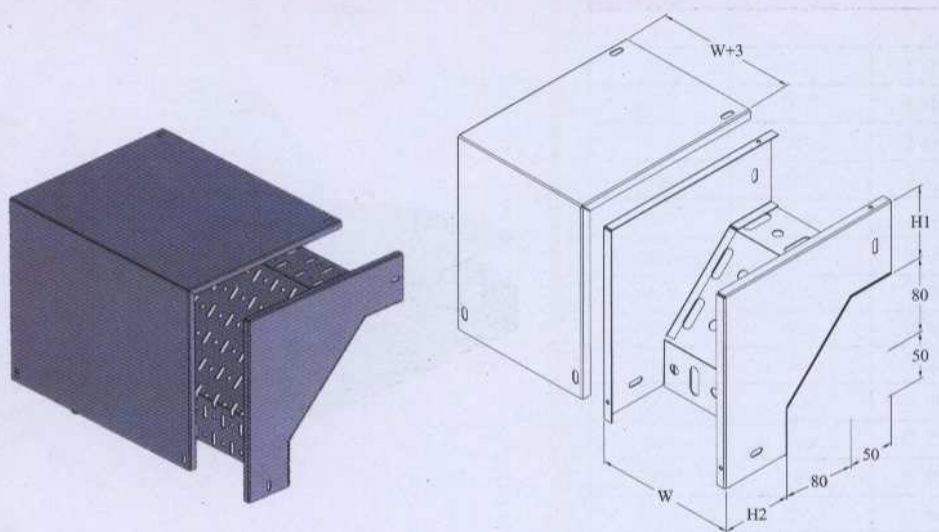

**MATERIAL** : Cold roll steel , Hot roll steel , Stainless steel  
**FINISHING** : EC (Epoxy powder coating) , HD (Hot dipped Galvanized) , AL (Aluzinc) , GI (Zinc)  
**COLOUR** : เทาเรียบ , เทาขุ่น , ครีมนุ่น , ครีมเรียบ , ขาวเรียบ  
**THICKNESS** : 0.8 , 1.0 , 1.2 , 1.6 , 2.0 mm.



## Horizontal Cross

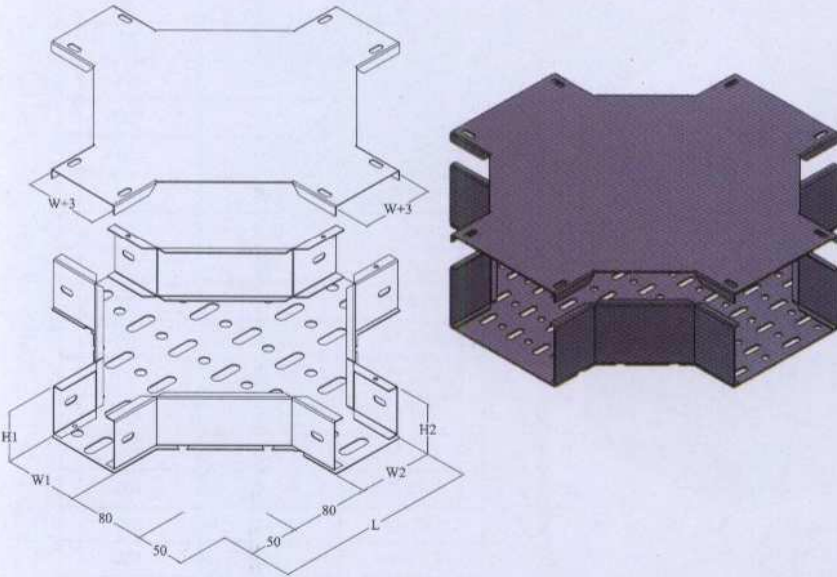

Code No.	Width (mm.)	Height (mm.)	Length (mm.)
PHC 1	75	50	335
PHC 2	100	50	360
PHC 3	100	75	360
PHC 4	100	100	360
PHC 5	150	100	410
PHC 6	200	100	460
PHC 7	250	100	510
PHC 8	300	100	560
PHC 9	350	100	610
PHC 10	400	100	660
PHC 11	450	100	710
PHC 12	500	100	760
PHC 13	550	100	810
PHC 14	600	100	860
PHC 15	650	100	910
PHC 16	700	100	960
PHC 17	800	100	1060
PHC 18	900	100	1160
PHC 18	1000	100	1260

**MATERIAL** : Cold roll steel , Hot roll steel , Stainless steel  
**FINISHING** : EC (Epoxy powder coating) , HD (Hot dipped Galvanized) , AL (Aluzinc) , GI (Zinc)  
**COLOUR** : เทาเรียบ ,เทาขุ่น , ครีมนุ่น , ครีมเรียบ , ขาวเรียบ  
**THICKNESS** : 0.8 , 1.0 , 1.2 , 1.6 , 2.0 mm.

Code No.	Width (mm.)	Height (mm.)
PHR 1	100	50
PHR 2	150	100
PHR 3	200	100
PHR 4	250	100
PHR 5	300	100
PHR 6	350	100
PHR 7	400	100
PHR 8	450	100
PHR 9	500	100
PHR 10	550	100
PHR 11	600	100
PHR 12	650	100
PHR 13	700	100
PHR 14	800	100
PHR 15	900	100
PHR 16	1000	100

## Horizontal Reduce

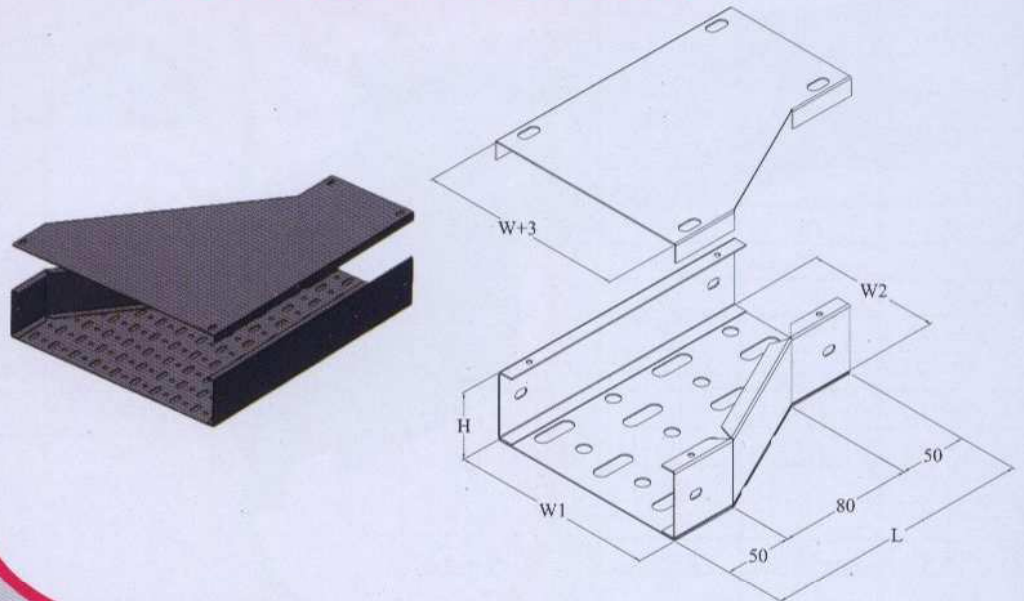

**MATERIAL** : Cold roll steel , Hot roll steel , Stainless steel  
**FINISHING** : EC (Epoxy powder coating) , HD (Hot dipped Galvanized) , AL (Aluzinc) , GI (Zinc)  
**COLOUR** : เทาเรียบ ,เทาขุ่น , ครีมนุ่น , ครีมเรียบ , ขาวเรียบ  
**THICKNESS** : 0.8 , 1.0 , 1.2 , 1.6 , 2.0 mm.